

Universal Load Cell



FEATURES

- Capacities: 50 - 5000kg, 100 - 10Klbs
- Fully welded, stainless steel construction
- Hermetically sealed, IP66 and IP68
- Certified to OIML R-60, 3000d
- Integrated overload stop (50 - 500kg)
- Current calibration output (SC version) ensures easy and accurate parallel connection of multiple load cells

OPTIONAL FEATURE

- ATEX and FM certified versions are available for use in potentially explosive atmospheres

DESCRIPTION

The BSP is a stainless steel S-type load cell that can be used in either tension or compression.

This product is suitable for a wide range of hybrid scales, overhead track scales, belt scales and process weighing applications.

The fully welded construction and water block cable entry ensure that this product can be used successfully in the harsh environments found in the food, chemical and allied process industries.

This product fully meets the stringent European Weights and Measures requirements through Europe.

APPLICATIONS

- Hybrid scales
- Process weighing
- Belt checkweighers
- Dynamometers
- Material testing machines

OUTLINE DIMENSIONS in mm

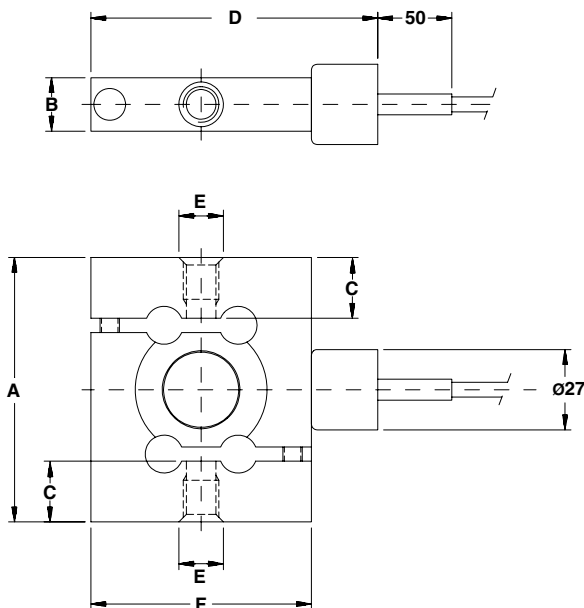

Cable specifications:

Cable length:	10m
Excitation +	Green
Excitation -	Black
Output +	White
Output -	Red
Shield	Transparent

Cable screen is not connected to load cell body. Performance may be affected if load cell cables are shortened. Tension applications result in a negative output signal.

Capacity (kg)	50, 125	250	500	1250	2500, 5000
A	84.3	88.9	88.9	95.2	120.6
B	23.9	18.0	18.0	24.1	36.6
C thread	12.7	14.0	14.0	14.0	29.2
D	85.7	84.1	96.8	84.1	84.1
E	M8x1.25		M12x1		M24x2
F	63.5	61.9	74.6	61.9	61.9

Capacity (lb)	100, 250	500	1K	2.5K	5K, 10K
A	3.32	3.50	3.50	3.75	4.75
F	2.48	2.44	2.94	2.44	2.44
B	0.94	0.71	0.71	0.95	1.44
D	3.36	3.32	3.81	3.31	3.31
E threads	3/8-24 UNF-3B		1/2-20 UNF-3B		1-14 UNS-3B

SPECIFICATIONS

PARAMETER	VALUE			UNIT
	NTEP IIII	Non-Approved	C3	
Standard capacities (E_{max})	50, 125, 250, 500, 1250, 2500, 5000			kg
Standard capacities (E_{max})	100, 250, 500, 1000, 2500, 5000, 10000			lbs
Accuracy class according to OIML R-60 /NTEP	NTEP IIII	Non-Approved	C3	
Max. no. of verification intervals	10000		3000	
Min. verification interval ($V_{min}=E_{max}/Y$)			$E_{max}/10000$	
Rated output (=S)	3 (2 for 2500 and 5000kg)			mV/V
Rated output tolerance	0.03 (0.02 for 2500 and 5000kg)			±mV/V
Zero balance	1.0			±% FSO
Combined error	0.0200	0.0500	0.0200	±% FSO
Non-repeatability	0.0100	0.0200	0.0100	±% FSO
Minimum dead load output return		0.0500	0.0167	±% FSO
Creep error (30 minutes)		0.0600	0.0245	±% FSO
Creep error (20 - 30 minutes)	0.0300	0.0200		±% FSO
Temp. effect on min. dead load output	(0.0008)	0.0250	0.0070	±% FSO/5°C (°F)
Temperature effect on sensitivity	(0.0010)	0.0250	0.0050	±% FSO/5°C (°F)
Minimum dead load	0			% E_{max}
Maximum safe over load	150			% E_{max}
Ultimate over load	300			% E_{max}
Maximum safe side load	100			% E_{max}
Deflection at E_{max}	0.28 max.			mm
Excitation voltage	5 to 15			V
Maximum excitation voltage	18			V
Input resistance	350±3.5			Ω
Output resistance	350±3.5			Ω
Insulation resistance	≥5000			MΩ
Compensated temperature range	-10 to +40			°C
Operating temperature range	-40 to +80			°C
Storage temperature range	-40 to +90			°C
Element material (DIN)	Stainless steel 1.4542			
Sealing (DIN 40.050 / EN60.529)	IP66 and IP68			
SC-Version (current calibration)	Standard			

FSO-Full Scale Output

SC-version: The rated output and the output resistance are balanced in such a way, that the output current is calibrated to within 0.05% of a reference value. This allows easy parallel connection of the load cells.

Disclaimer

All product specifications and data are subject to change without notice.

Vishay Precision Group, Inc., its affiliates, agents, and employees, and all persons acting on its or their behalf (collectively, "Vishay Precision Group"), disclaim any and all liability for any errors, inaccuracies or incompleteness contained herein or in any other disclosure relating to any product.

Vishay Precision Group disclaims any and all liability arising out of the use or application of any product described herein or of any information provided herein to the maximum extent permitted by law. The product specifications do not expand or otherwise modify Vishay Precision Group's terms and conditions of purchase, including but not limited to the warranty expressed therein, which apply to these products.

No license, express or implied, by estoppel or otherwise, to any intellectual property rights is granted by this document or by any conduct of Vishay Precision Group.

The products shown herein are not designed for use in medical, life-saving, or life-sustaining applications unless otherwise expressly indicated. Customers using or selling Vishay Precision Group products not expressly indicated for use in such applications do so entirely at their own risk and agree to fully indemnify Vishay Precision Group for any damages arising or resulting from such use or sale. Please contact authorized Vishay Precision Group personnel to obtain written terms and conditions regarding products designed for such applications.

Product names and markings noted herein may be trademarks of their respective owners.